

CATHOLIC HIGH SCHOOL
MID-YEAR EXAMINATION (2022)
PRIMARY SIX
SCIENCE
BOOKLET A

Name: _____ ()

Class: Primary 6 - _____

Date: 12 May 2022

28 questions

58 marks

Total Time for Booklets A and B: 1 hour 45 minutes

INSTRUCTIONS TO CANDIDATES

Do not turn over this page until you are told to do so.
Follow all instructions carefully.

Answer all questions.

Shade your answers in the Optical Answer Sheet (OAS) provided.

This booklet consists of 18 printed pages, excluding the cover page.

Booklet A (28 × 2 marks)

For each question from 1 to 28, four options are given. One of them is the correct answer. Make your choice (1, 2, 3 or 4). Shade your answer on the Optical Answer Sheet. (56 marks)

1 The diagram below shows how organisms A, B, C and D are grouped.

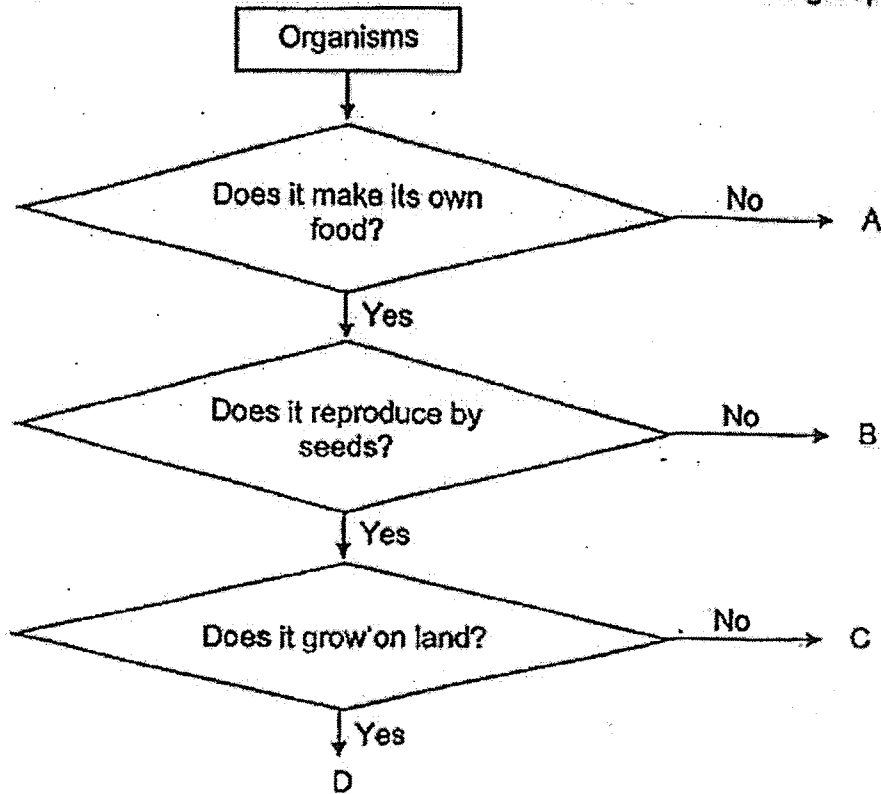

The table below shows some characteristics of organisms X, Y and Z. A tick (✓) indicates the presence of the characteristics in the organism.

Characteristics	Organism X	Organism Y	Organism Z
has fruits			
grows on land			
has chlorophyll			
reproduces by spores			

Based on the information above, which organism(s) share(s) the same characteristics as organism C?

- (1) Y only
- (2) X and Y only
- (3) X and Z only
- (4) X, Y and Z

- 2 The graph below shows the amount of undigested food before it enters the parts of the human digestive system. Parts P, Q, R and S are not labelled in sequence.

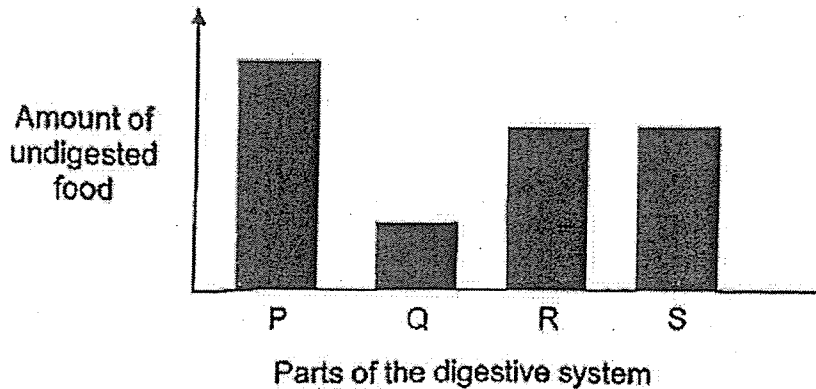

Which of the following correctly identifies parts P, Q, R and S?

	P	Q	R	S
(1)	gullet	small intestine	stomach	mouth
(2)	mouth	small intestine	gullet	stomach
(3)	mouth	gullet	small intestine	stomach
(4)	mouth	gullet	stomach	small intestine

- 3 The life cycle of a plant is shown below.

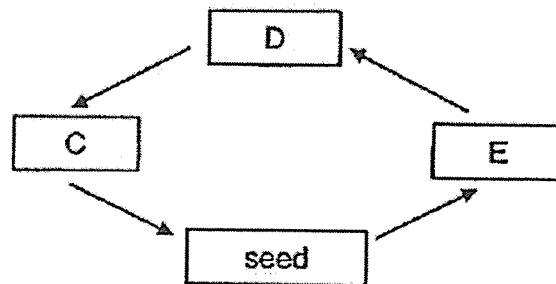

Which observations correctly describe stages C, D and E?

	C	D	E
(1)	root and shoot appear	flower appears	fruit appears
(2)	fruit appears	root and shoot appear	flower appears
(3)	flower appears	fruit appears	root and shoot appear
(4)	fruit appears	flower appears	root and shoot appear

- 4 The graph below shows the time insect K spends at different stages of its life.

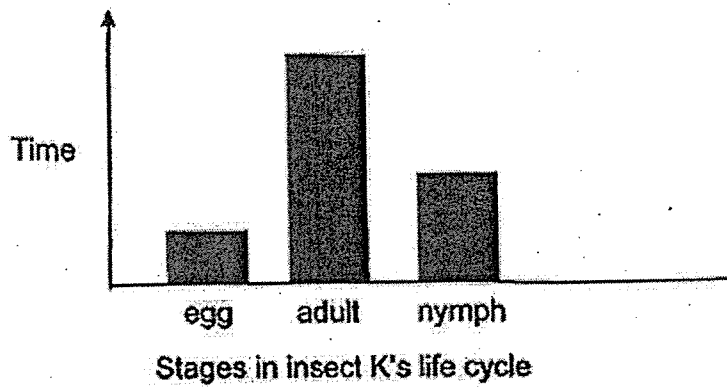

Which statement(s) can be concluded from the graph?

- A The nymph does not look like the adult.
- B Insect K undergoes a three-stage life cycle.
- C The nymph stage is spent in water but the adult stage is spent on land.

- (1) A only
- (2) B only
- (3) A and C only
- (4) B and C only

- 5 The diagram below shows the different stages of the growth of a seed into a seedling.

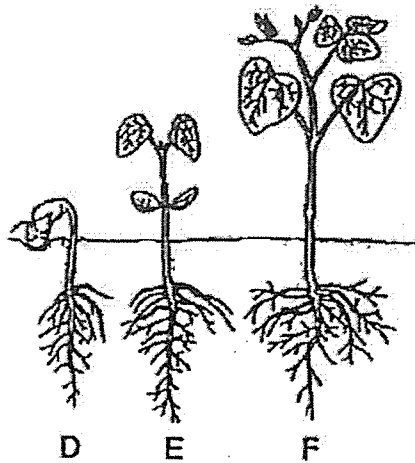

At which stage(s) can the seedling make its own food?

- (1) D only
 - (2) F only
 - (3) E and F only
 - (4) D, E and F
- 6 A flowering plant undergoes processes R, S and T as shown below.

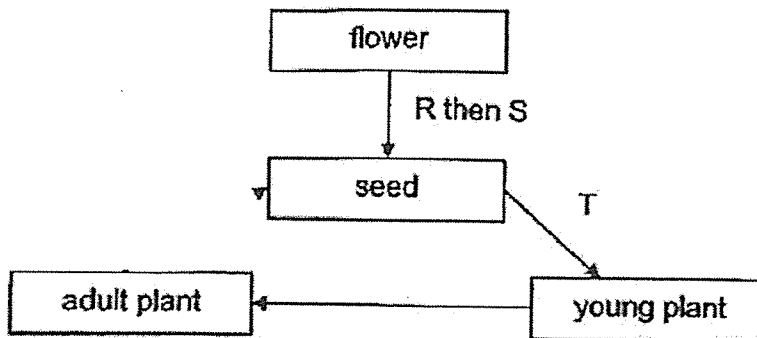

Process R must occur before Process S.

Which are processes R, S and T?

	R	S	T
(1)	fertilisation	pollination	germination
(2)	pollination	germination	fertilisation
(3)	pollination	fertilisation	seed dispersal
(4)	fertilisation	pollination	seed dispersal

7 The diagrams below show the reproductive parts of a human and plant.

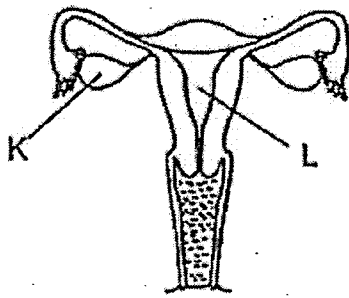

human reproductive system

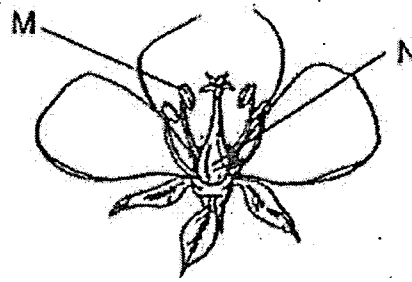

plant reproductive system

Which statement is correct?

- (1) Fertilisation occurs in K and N.
- (2) The young develops in L and M.
- (3) K and M produce reproductive cells.
- (4) K and N produce male reproductive cells.

8 The diagram below shows how water and food are transported to and from parts A, B and C of a plant.

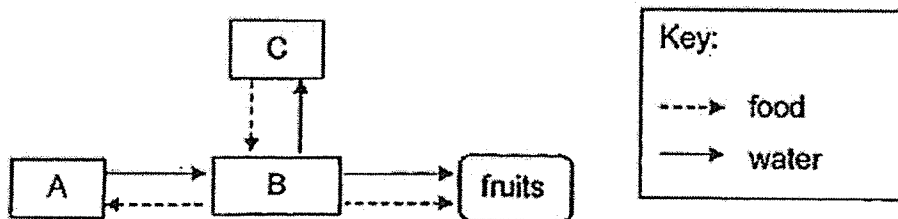

Which do A, B and C represent?

	A	B	C
(1)	stem	roots	leaves
(2)	roots	stem	leaves
(3)	leaves	roots	flowers
(4)	flowers	leaves	stem

9 Which of the following statement(s) about human, fish and plants is/are not correct?

- A The gullet and gills are part of the respiratory system.
- B Gaseous exchange happens at the lungs, gills and stomata.
- C Blood transports carbon dioxide and oxygen in human and fish.

- (1) A only
- (2) A and B only
- (3) B and C only
- (4) A, B and C

10 Which is the basic unit of life for a tree and a fish respectively?

	Tree	Fish
(1)	cell wall	cell membrane
(2)	nucleus	nucleus
(3)	chloroplast	nucleus
(4)	cell	cell

- 11 Patricia carried out an experiment to find out how the amount of carbon dioxide taken in affects the rate of photosynthesis in a plant.

Which of the following correctly shows the results of her experiment if she had carried out a fair test?

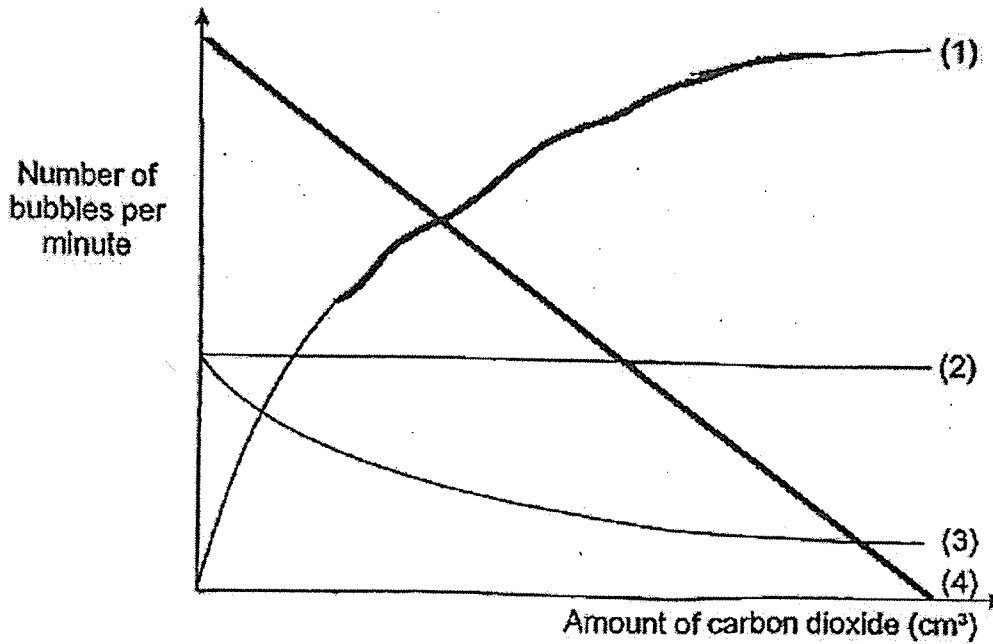

- 12 The letters below represent organisms in a community and the arrows show the direction of the flow of energy.

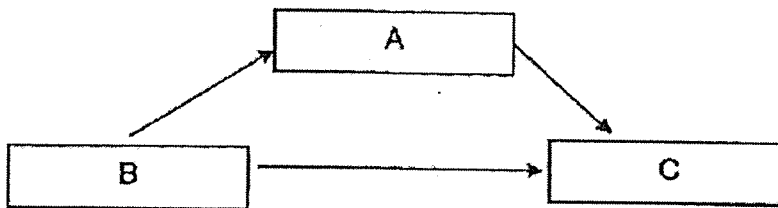

Which of the following correctly represents A, B and C in this community?

	A	B	C
(1)	plants	decomposers	animals
(2)	animals	decomposers	plants
(3)	animals	plants	decomposers
(4)	decomposers	plants	animals

- 13 The characteristics of environment X are listed in the table below.

Environment X	
temperature	23°C
light intensity	0 units to 8 units
amount of oxygen	very little
amount of carbon dioxide	high

The table below shows the characteristics of the preferred habitats of three organisms D, E and F.

Organisms	Characteristics of preferred habitat		
	Temperature	Light Intensity	Air
D	15°C to 25°C	11 units	rich in oxygen
E	20°C to 30°C	5 units	rich in carbon dioxide
F	any temperature	3 units	poor in oxygen

Which organism(s) D, E or F can live in environment X?

- (1) D only
- (2) E only
- (3) D and F only
- (4) E and F only

14 Which diagram is correct?

(1)

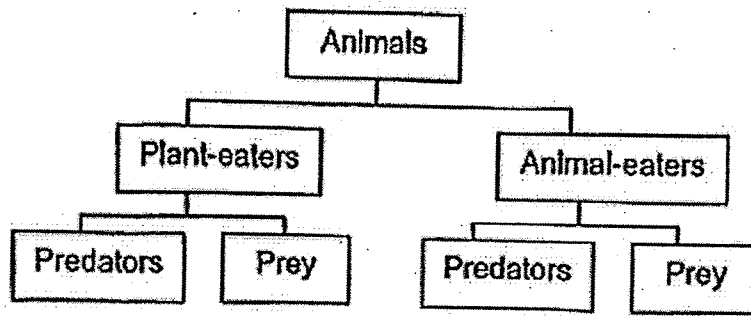

(2)

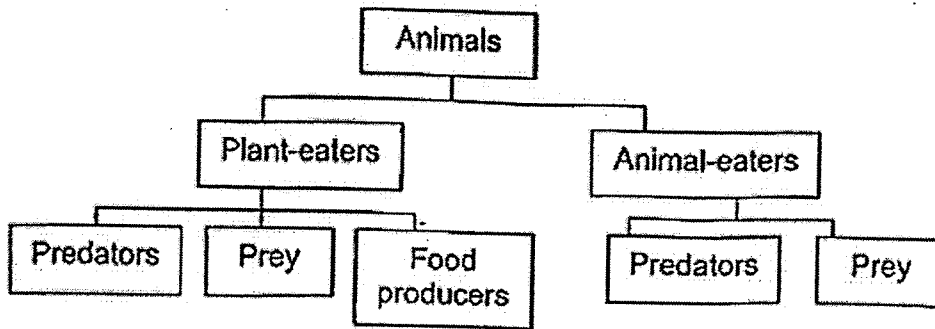

(3)

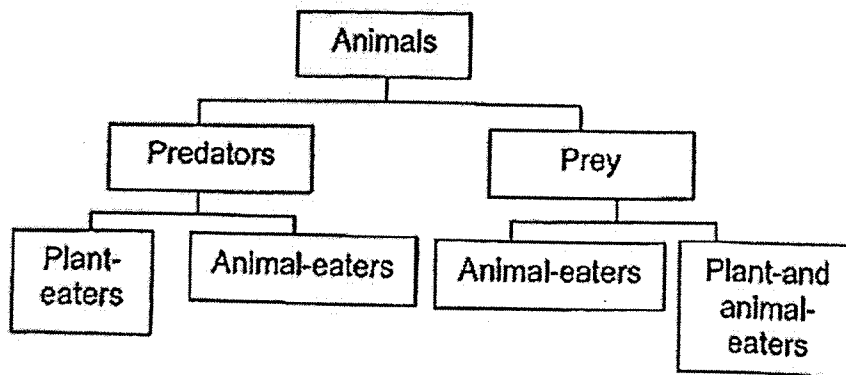
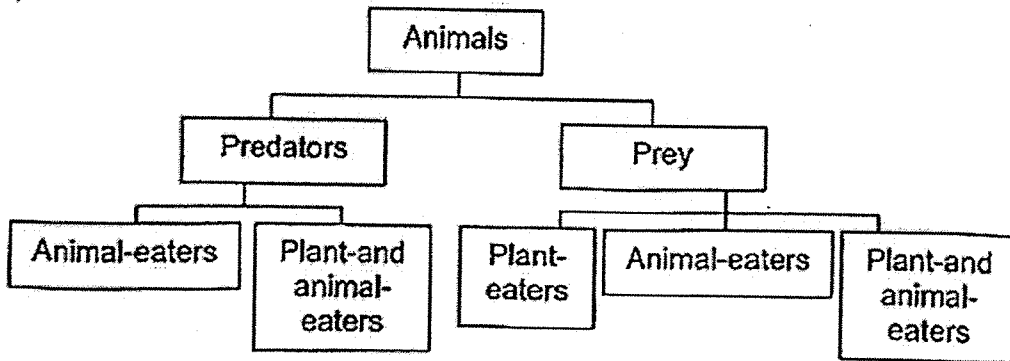

- 15 The food web below shows the food relationship among various organisms in a particular community.

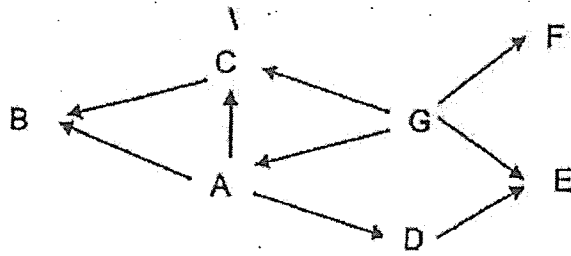

Based on the food web above, which observation is correct?

	Statements	Observations		
		True	False	Not possible to tell
(1)	B and G are plants.			✓
(2)	D is a food producer.			
(3)	E does not have any predators feeding on it.			✓
(4)	There are three animals which eat both plants and animals.			

- 16 Which statements correctly describe the structural and behavioural adaptations of some organisms?

	Structural adaptation	Behavioural adaptation
(1)	moves slowly to avoid predators	coils up to avoid predators
(2)	uses big eyes to hunt in darkness	uses big ears to hunt in darkness
(3)	lays eggs in corners to increase the chances of survival	lays many eggs to increase the chances of survival
(4)	uses colour on its body to blend in with the surroundings	uses twigs to decorate its shell to blend in with the surroundings

- 17 Animal G is covered in a shell that supports its body and protects its organs. This shell is made of material H.

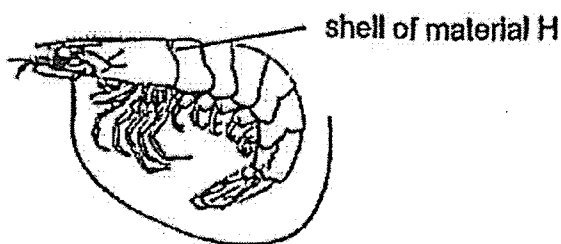

Which property of material H allows the shell to perform the functions described?

- (1) strength
 - (2) flexibility
 - (3) waterproof
 - (4) ability to float
- 18 Some stones were placed into a measuring cylinder as shown in the diagram below.

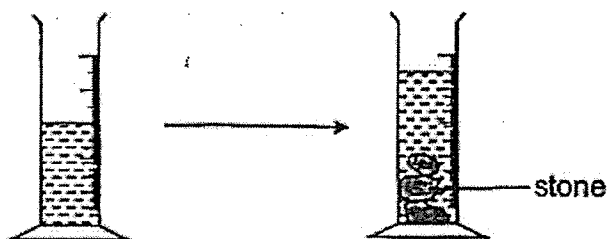

Which statements best explain the change in the water level?

- A Water has a definite volume.
- B Stones have a definite shape.
- C Stones take up space in the water.

- (1) A and B only
- (2) A and C only
- (3) B and C only
- (4) A, B and C

19 Identical batteries and bulbs are used to set up the four circuits.

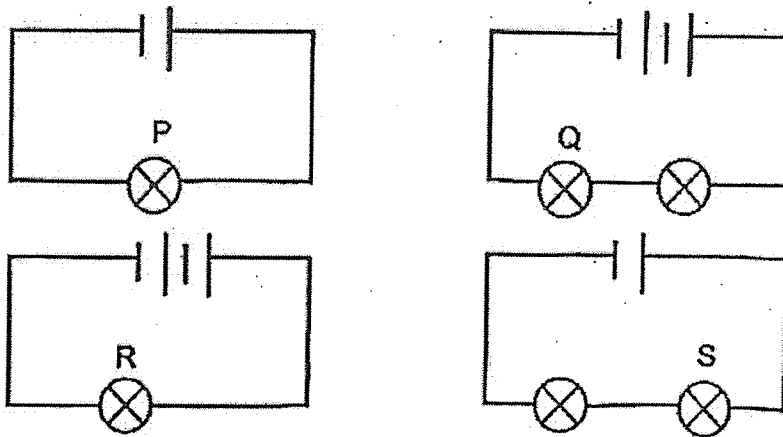

Which of the following is correct about the brightness of the bulbs?

Brightness of bulb			
	Low	Medium	High
(1)	S	P	Q
(2)	S	Q	R
(3)	Q	R	S
(4)	Q	P	R

20 Study the water cycle.

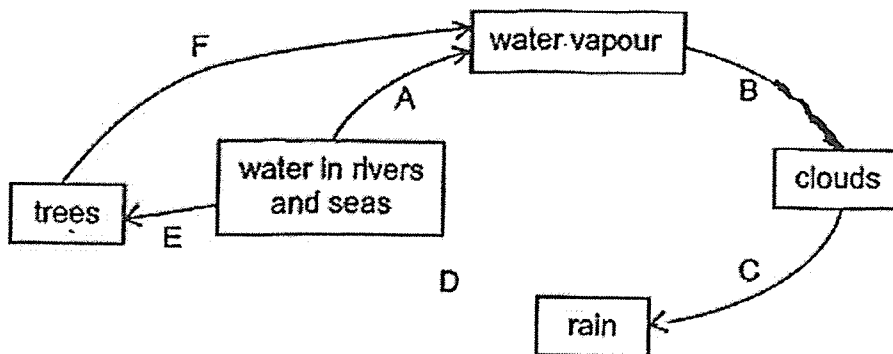

Which of the following is correct?

	Involve a change in state	Involves heat loss
(1)	A and B	B
(2)	C and F	C
(3)	A, C, D and E	B
(4)	B, D, E and F	C

21 Timothy lit up one end of a block.

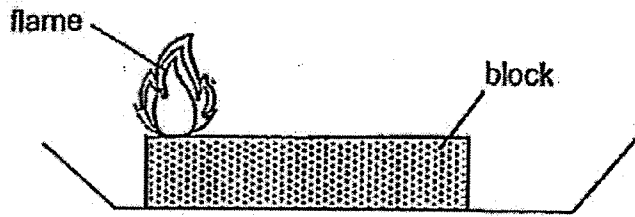

Which of the following shows the energy changes during burning?

- (1) heat energy in block → light energy
- (2) heat energy in flame → light energy + kinetic energy
- (3) potential energy in block → heat energy + light energy
- (4) potential energy in flame → heat energy + kinetic energy

22 Peter set up an experiment as shown below. He placed the torch at position A and the cardboard at position D.

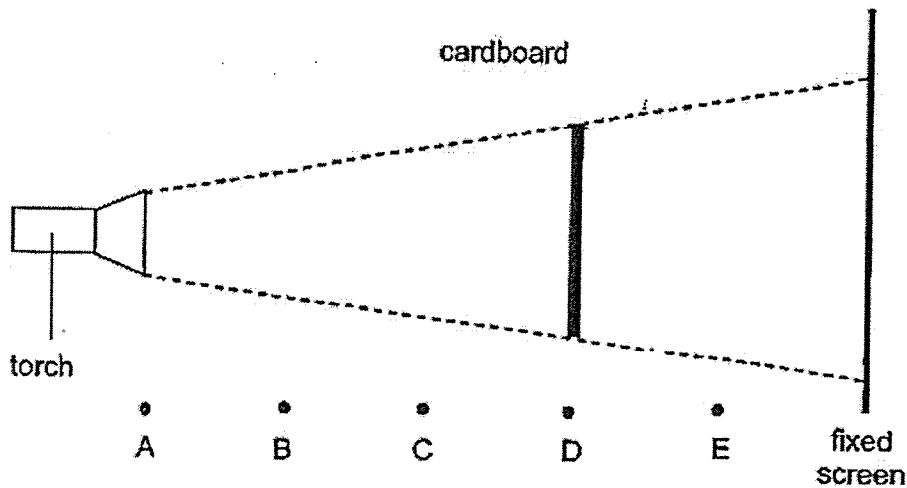

At which positions should Peter place the torch and the cardboard in order to decrease the height of the shadow on the screen?

	Position of torch	Position of cardboard
(1)	A	C
(2)	A	E
(3)	B	D
(4)	B	C

- 23 Amy set up an experiment as shown below. She used two similar strong magnets A and B. Magnet A was attached to a spring while magnet B was fixed to an electronic balance.

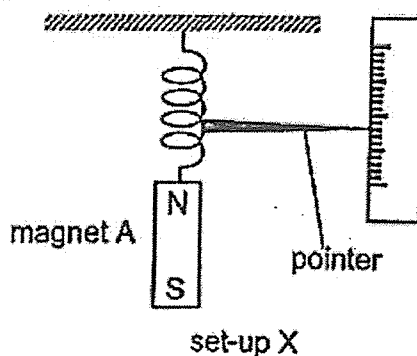

Amy then moved set-up Y such that magnet A was directly above magnet B.

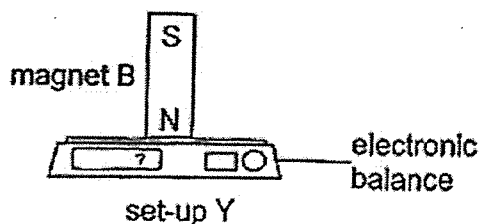

Which of the following best represents her observations?

	Movement of pointer	Reading on the balance
(1)	downwards	decreases
(2)	downwards	increases
(3)	upwards	decreases
(4)	upwards	increases

- 24 The table shows the melting and boiling points of substances X and Y.

Substance	X	Y
melting point ($^{\circ}\text{C}$)	28	40
boiling point ($^{\circ}\text{C}$)	80	90

At which temperature are substances X and Y in different states of matter?

- (1) 25°C
- (2) 30°C
- (3) 55°C
- (4) 100°C

25 Zainal wanted to investigate how different types of material used to make the cups affect the time taken for the ice cubes to melt completely. He placed the three cups X, Y and Z in a classroom.

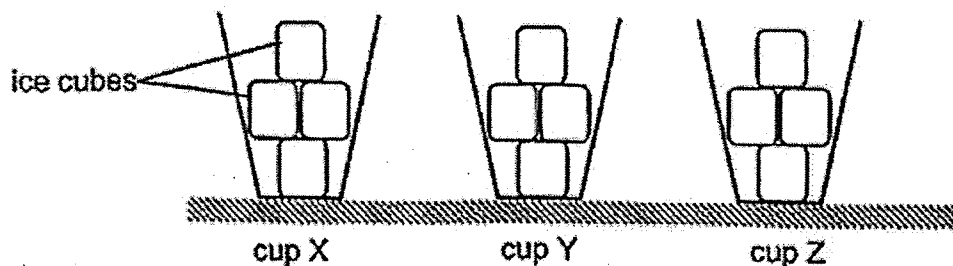

He recorded his observations in the table below.

Cup	State of ice		
	20 min	40 min	60 min
X	solid	solid	liquid
Y	solid	liquid	liquid
Z	liquid	liquid	liquid

Based on his results, which statements are correct?

- A Z is the best conductor of heat.
- B X is the poorest conductor of heat.
- C Y is a better conductor of heat than Z.
- D Y is a poorer conductor of heat than X.

- (1) A and B only
- (2) A and D only
- (3) B and C only
- (4) C and D only

26 The diagram below shows how a swing moves from point A to point B and to point C.

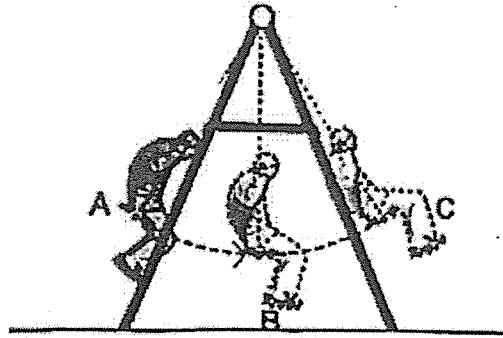

Which graph shows the correct changes in energy of the swing as the swing moves from point A to point B and to point C?

Key:
 — kinetic energy
 - - - potential energy

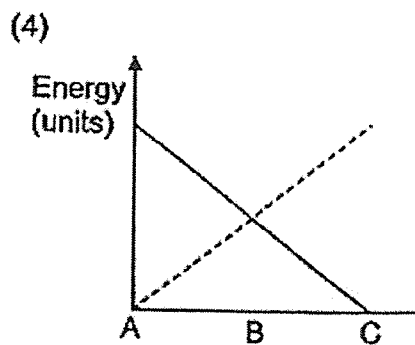
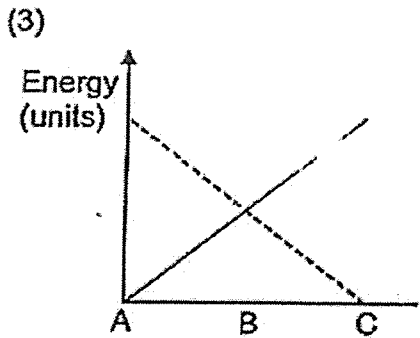
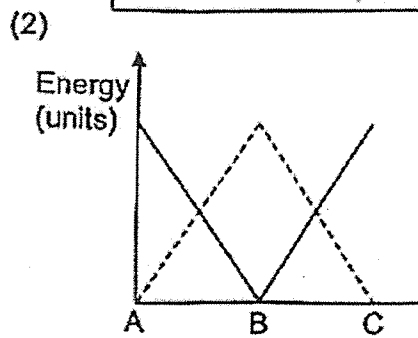
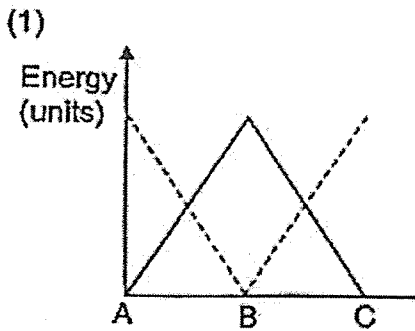

- 27 A ball was released from the top of a ramp. The diagram shows the ball at three different points as it rolled down the ramp.

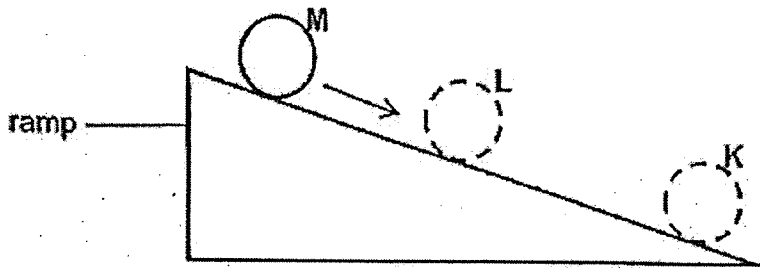

Based on the diagram, which statements are correct?

- A The ball at position L has more kinetic energy than the ball at position M.
 - B The ball at position K has lesser kinetic energy than the ball at position M.
 - C The ball at position M has more gravitational potential energy than the ball at position L.
 - D The ball at position L has lesser gravitational potential energy than the ball at position K.
- (1) A and D only
 - (2) A and C only
 - (3) B and D only
 - (4) B and C only

- 28 Ravi placed a wooden block on a wooden plank XY horizontally on a table as shown in Diagram 1.

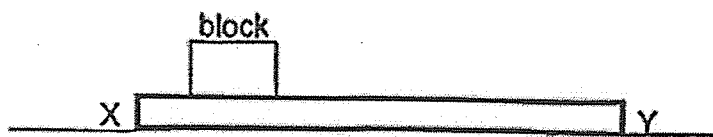

Diagram 1

He raised end X of the plank slightly but the block did not move as shown in Diagram 2.



Diagram 2

When raised higher, the block started sliding down as shown in Diagram 3.

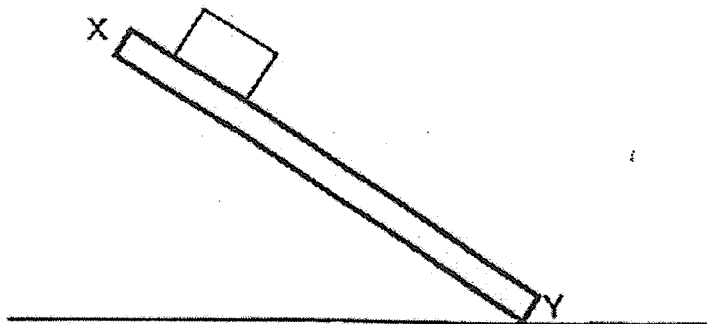

Diagram 3

Which statement(s) is/are correct?

- A Gravitational force acted on the block in Diagram 1.
 - B Frictional force acted on the block when the plank was raised in Diagram 2.
 - C Frictional force acted on the block when the block was sliding down the plank in Diagram 3.
- (1) B only
(2) C only
(3) A and C only
(4) A, B and C

End of Booklet A



CATHOLIC HIGH SCHOOL
MID-YEAR EXAMINATION (2022)
PRIMARY SIX
SCIENCE
BOOKLET B

Name: _____ ()

Class: Primary 6 - _____

Date: 12 May 2022

Parent's Signature: _____

Booklet A	56
Booklet B	44
Total	100

13 questions

44 marks

Total Time for Booklets A and B: 1 hour 45 minutes

INSTRUCTIONS TO CANDIDATES

Do not turn over this page until you are told to do so.

Follow all instructions carefully.

Answer all questions.

Write your answers in this booklet.

This booklet consists of 17 printed pages, excluding the cover page.

Booklet B (44 marks)

For questions 29 to 41, write your answers in this booklet.

The number of marks available is shown in brackets [] at the end of each question or part question. (44 marks)

- 29 The diagram below shows the location of the young of plant H over a period of six months.

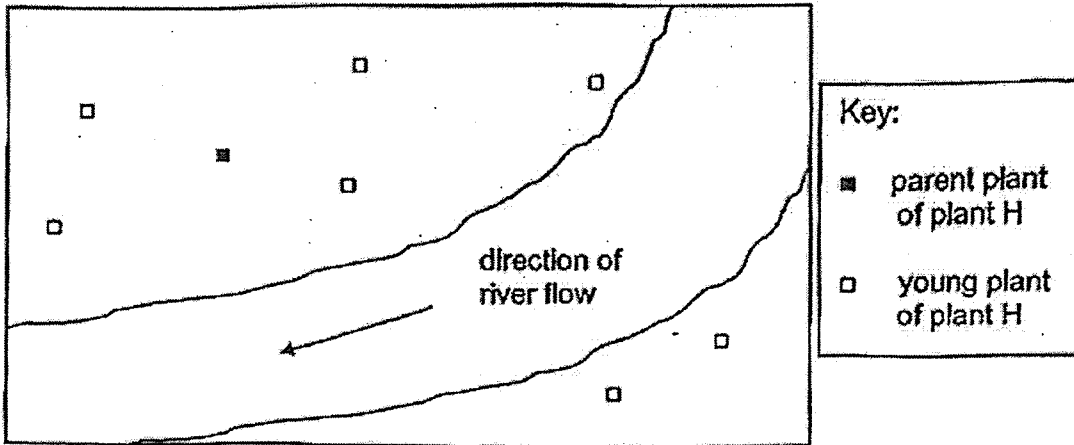

- (a) State the dispersal method of plant H. [1]

- (b) State a characteristic of the fruit of plant H and explain how it helps in its dispersal as seen in the diagram. [1]

(Go on to the next page)

SCORE	2
-------	---

- 30 Mrs How placed two similar plants in identical flasks and put them in a sunny area. These plants have tiny openings on the leaf surfaces known as stomata. Water is lost through the stomata in the form of water vapour.

She coated one side of all the leaves with oil for the plant in set-up W and coated the other side of all the leaves with oil for the plant in set-up X.

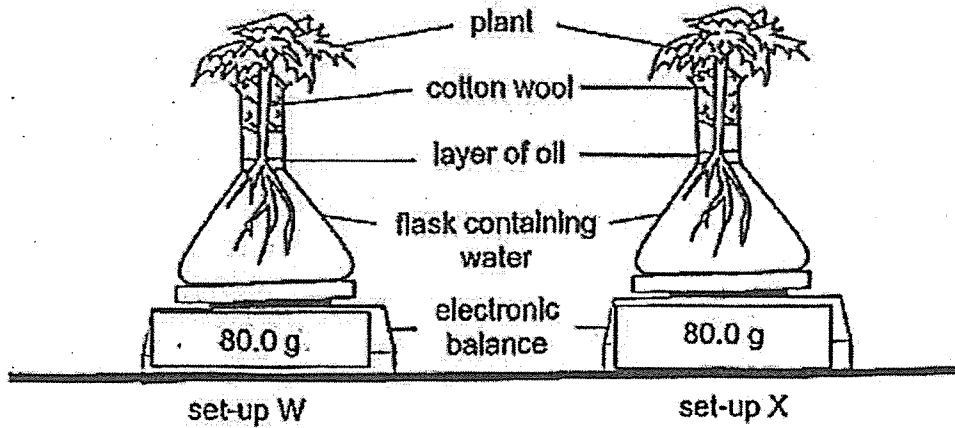

The table below shows the mass of the set-ups at the beginning and at the end of the experiment after a day.

Set-up	Mass (g)	
	Start of experiment	End of experiment
W	80.0	65.0
X	80.0	50.0

- (a) Based on the results above, which flask contained the plant with leaves that were coated with oil on the underside? Explain why. [2]

- (b) Mrs How placed the same set-ups in a dark room and noticed that the readings were higher. Explain why. [1]

(Go on to the next page)

SCORE	3
-------	---

- 31 The table below shows the amount of oxygen in the air at different heights above the sea level.

Height above sea level (m)	Amount of oxygen available in the air (%)
0	20.9
1000	18.4
4000	11.9
9500	6.8

- (a) Based on the information, what is the relationship between the height above sea level and the amount of oxygen available in the air? [1]

- (b) Based on the information, explain why someone at 8800 m above sea level will have a heart rate faster than when he is at sea level. [2]

(Go on to the next page)

SCORE	3
-------	---

32 The diagram below shows the stages of a seed's growth.

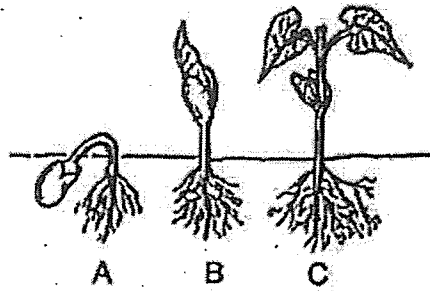

The graph below shows the change in the mass of the seedling and its seed leaves during the experiment.

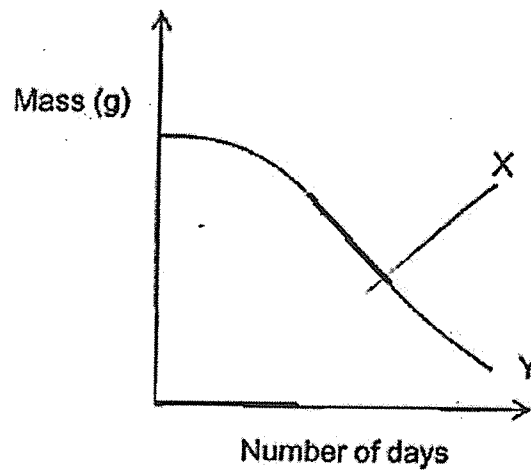

(a) State the conditions required for germination. [1]

(b) Which line X or Y shows the change in the mass of the seed leaves from stage A to stage C? Explain. [1]

(c) Describe the process of photosynthesis in green plants. [1]

(Go on to the next page)

SCORE	3
-------	---

33 Mangrove trees are found in muddy swamps where there are frequent rough tides and strong winds.

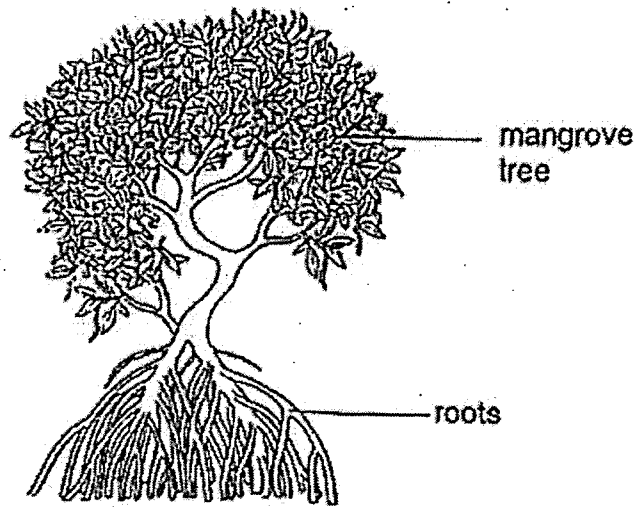

- (a) The mangrove trees have roots that are widespread as shown in the diagram above. How do the widespread roots help the trees to survive the frequent rough tides and strong winds in its environment? [1]

The seed of a mangrove tree germinates into a young plant while it is still attached to the parent plant as shown in the diagram below.

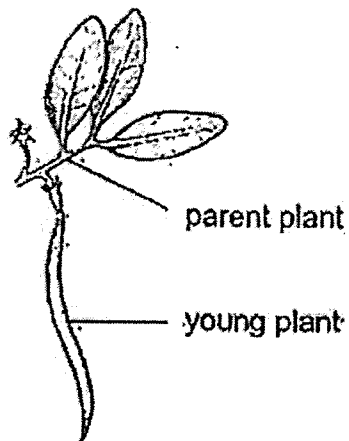

(Go on to the next page)

SCORE	1
-------	---

Continue from Question 33

The diagram below shows what happens to the young plant during dispersal.

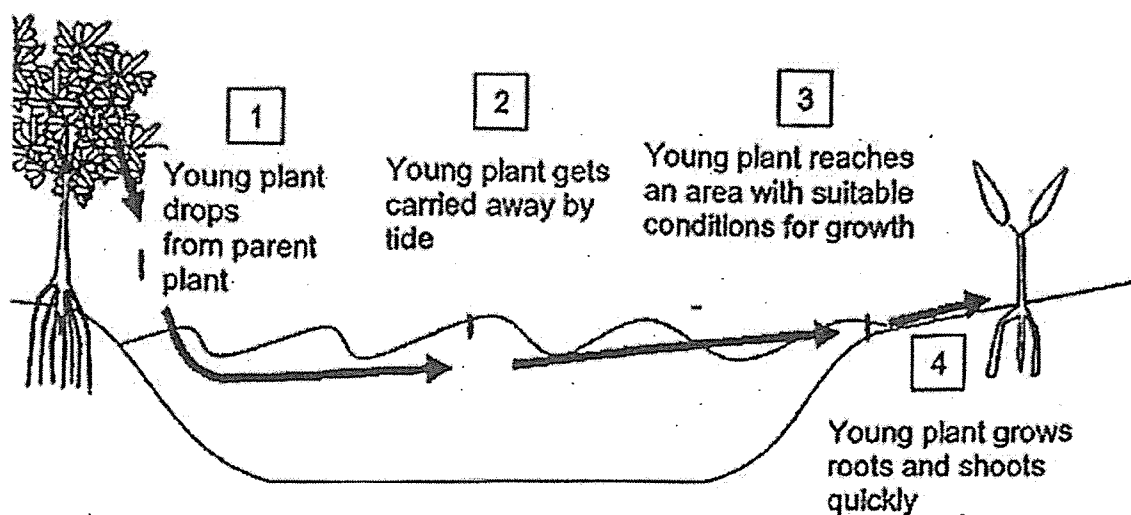

(b) Based on the diagram, suggest two benefits of the seed germinating while it is still attached to the parent plant. [2]

Suggestion 1: _____

Suggestion 2: _____

0

(Go on to the next page)

SCORE	2
-------	---

34 The food web below shows the food relationships among organisms in a habitat.

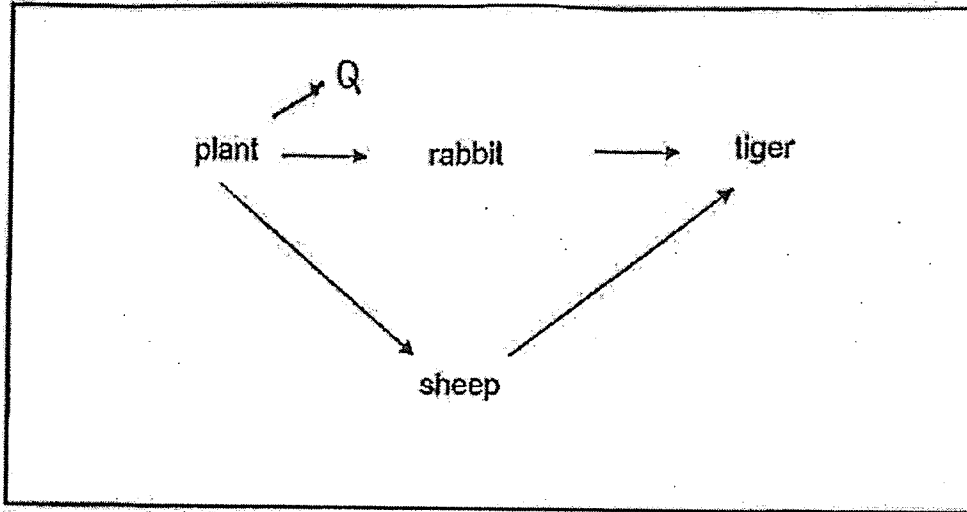

The diagram below shows the jawbone of animal Q.

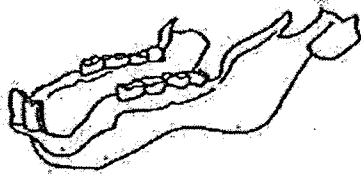

(a) Based on your observation of the jawbone, add animal Q in the food web above.

[1]

(b) Organism R which feeds on rabbits are introduced to the habitat above. Explain how the addition of organism R will affect the population of the sheep.

[2]

(Go on to the next page)

SCORE	3
-------	---

Continue from Question 34

A tiger has stripes on its body that helps it to prey on sheep.

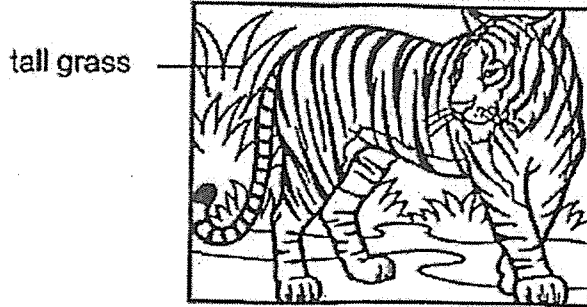

- (c) Based on the information, state the type of adaptation and explain how it helps the tiger to prey on sheep. [2]

(Go on to the next page)

SCORE	2
-------	---

35 Sarah designed a toy system as shown.

When both metal wheels on the toy car were in contact with the metal pins near iron rod A, the toy car would move towards iron rod B. When both wheels on the toy car touched the metal pins near iron rod B, the car would then move towards iron rod A again.

The toy car was able to move on the plastic track back and forth continuously on its own.

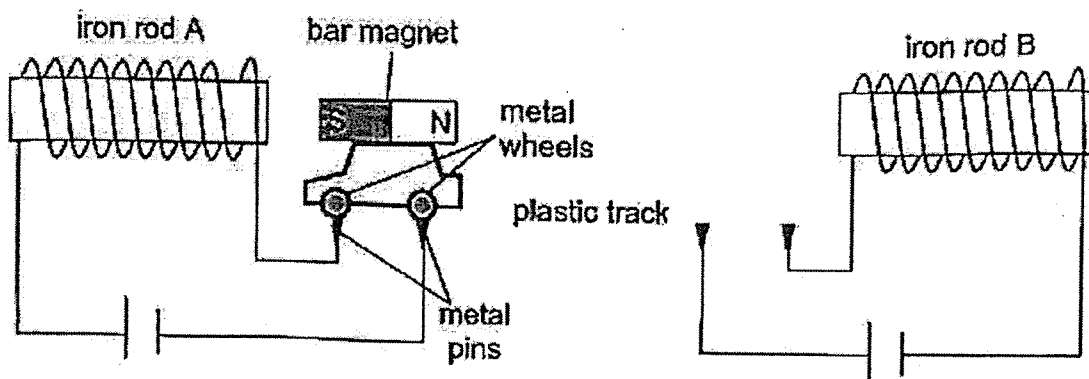

- (a) State a physical property of the metal wheel that makes it suitable for use as the wheels of the toy car in the system above. [1]

- (b) Explain how the toy car was able to move from iron rod A to B on its own. [2]

(Go on to the next page)

SCORE	3
-------	---

- 36 Faizah wanted to investigate how the distance between the material and the light source affects the amount of light reflected by the material. He set up an experiment in a completely dark room as shown.

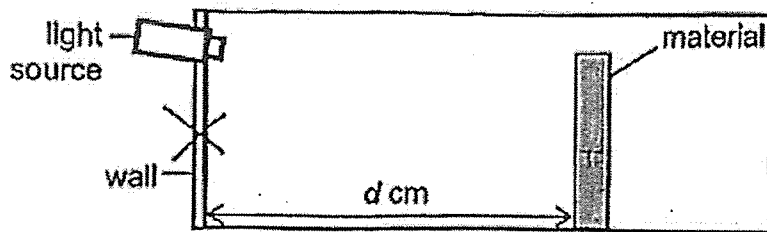

He varied the distance, d and recorded his results in the table below.

Distance, d (m)	Amount of light reflected (units)		
	Material W	Material X	Material Y
2	340	100	190
3	300	90	130
4	200	50	80

- (a) In the set-up above, mark 'X' on the wall to show where Faizah should place the light sensor to measure the amount of light reflected by the material. [1]
- (b) Suggest a reason why using the light sensor to measure the amount of light reflected by the material would improve the investigation. [1]

The diagram below shows a reflective vest that a cyclist wears at night.

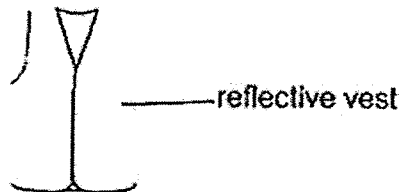

- (c) Based on his results, which material is most suitable to make the vest so that the cyclist can be seen from the furthest distance? Give a reason. [1]

(Go on to the next page)

SCORE	3
-------	---

37 (a) State what temperature is.

[1]

Ephraim filled eight identical test tubes with the same amount of water of the same temperature. He grouped the test tubes as shown below.

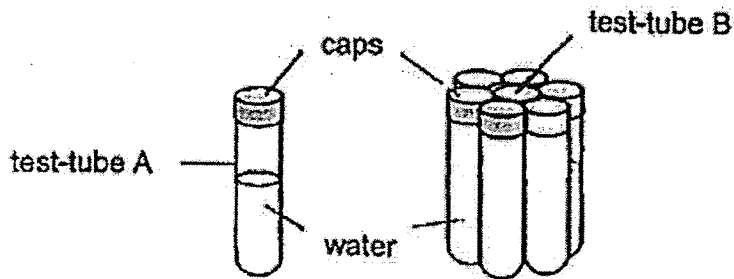

He measured the temperature of the water in the test tubes at 5-minute intervals and recorded the results in the table below.

Time (min)	Temperature of water (°C)	
	Test-tube A	Test-tube B
0	60	60
5	55	58
10	41	58
15	37	55
20	37	55

(b) State the temperature of the surroundings.

[1]

(c) Explain why the temperature of the water in test-tube B is higher than that in test-tube A after 20 minutes.

[1]

(Go on to the next page)

SCORE	3
-------	---

38. Minghao conducted an experiment using the set-ups below. He added the same amount of water onto four similar cloths A, B, C and D.

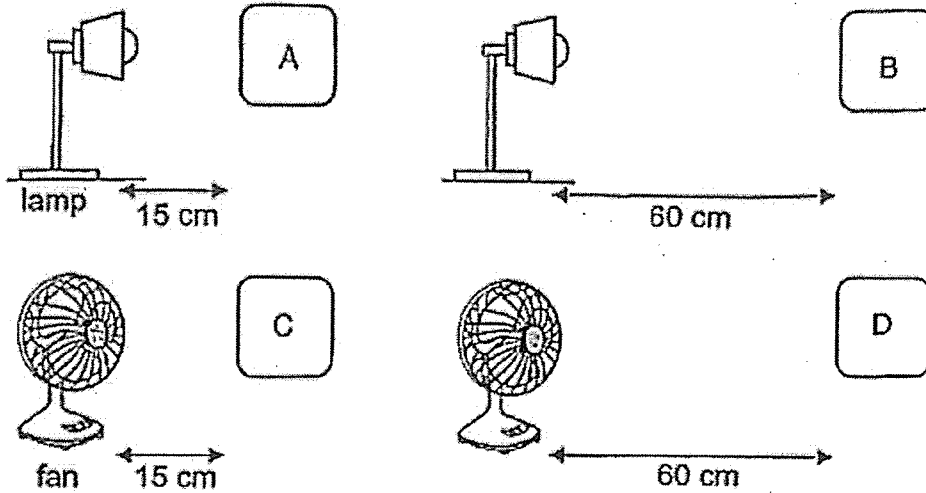

The graph shows the mass of the cloth over a period of time.

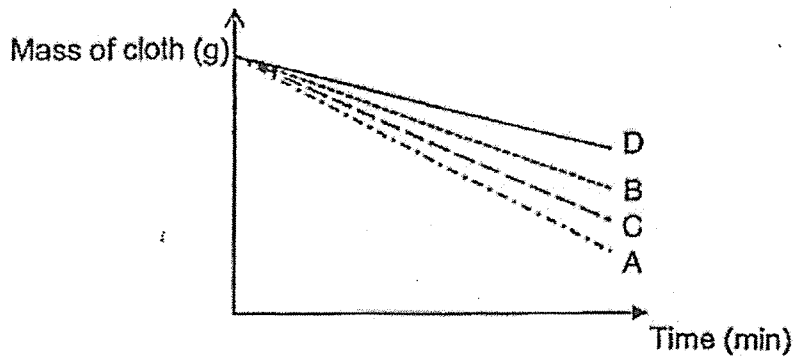

- (a) Based on the graph, explain how the different distances of the lamp from the cloth affect the mass of the cloth. [2]

- (b) Based on the graph, which variable, light or wind, has a smaller effect on the mass of the cloth? Give a reason for your answer. [1]

(Go on to the next page)

SCORE	3
-------	---

39 Bulbs B1, B2 and B3, and switches S1, S2 and S3 were connected in a circuit as shown. All the bulbs are working properly.

Different bulbs lit up when different switches were open and closed.

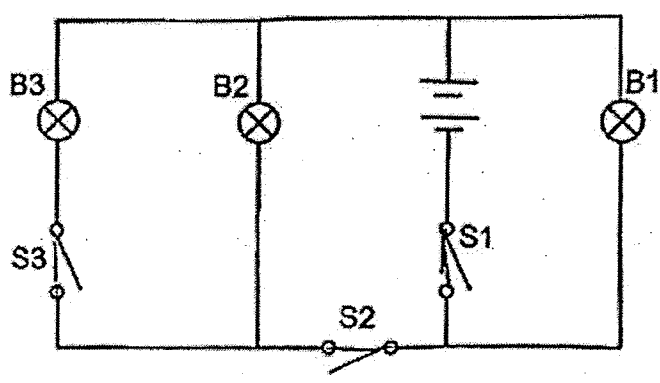

(a) Complete the table by filling in the four blanks below.

[2]

Switches			Did the bulb light up?		
S1	S2	S3	B1	B2	B3
closed	open	closed	(i)	no	no
open	closed	closed	no	no	(ii)
closed	closed	open	yes	(iii)	no
(iv)	closed	open	yes	yes	no

(Go on to the next page)

SCORE	2
-------	---

Continue from Question 39

Four rods A, B, C and D of different materials were connected in another circuit as shown below.

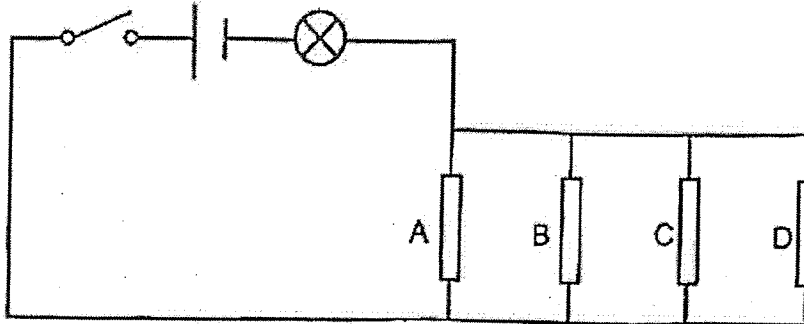

The table below shows what happened when the switch was closed and certain rod(s) was/were removed.

Rod(s) removed from circuit	Did the bulb light up?
A	yes
B and C	yes
A, B and C	no
A, C and D	no

- (b) Based on the information, what can you conclude about rods A, B, C and D? [2]

(Go on to the next page)

SCORE	2
-------	---

- 40 Ahmad conducted an experiment using the set-up below. He poured substance W onto the surface of the table. He then added slotted mass until the wooden block began to move across the surface of the table.

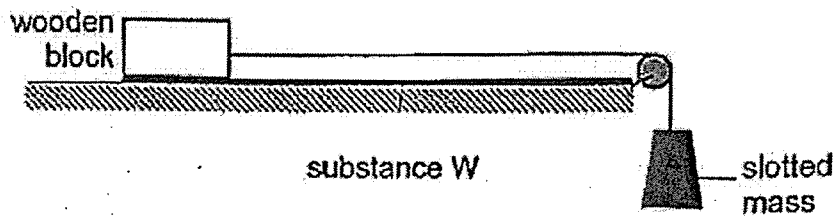

Ahmad repeated the experiment with the same block but with different substances X, Y and Z. His results are shown in the table below.

Substance	Mass required to move the wooden block (g)
W	190
X	130
Y	250
Z	90

- (a) State the force(s) that caused the block to move across the table. [1]

- (b) State two variables he needed to keep constant for the experiment. [1]

(Go on to the next page)

SCORE	2
-------	---

Continue from Question 40

Ahmad played a game with his friends. He used his fingers to flick the disc at the starting line forcing the disc to fall into any of the four corner pockets of the board.

He applied a substance onto the surface of the board before flicking his disc.

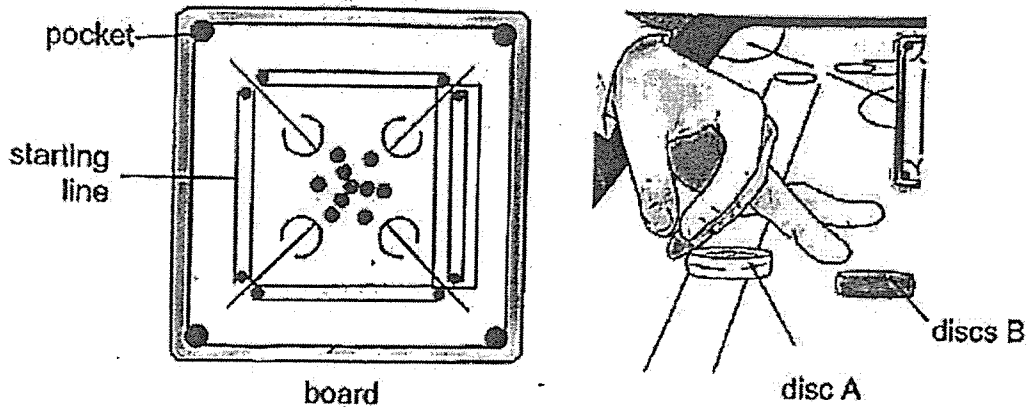

- (c) Based on the results, which substance W, X, Y and Z is most suitable to be applied on the board to help the disc move the furthest across the board? Explain your answer. [1]

When Ahmad applied a substance on the board, he noticed disc B moved further after being hit by disc A.

- (d) Explain how applying the substance on the board allowed disc B to move further. [1]

- (e) Explain in terms of energy changes why disc B was able to move further after being hit by disc A. [1]

(Go on to the next page)

SCORE	3
-------	---

- 41 An inflated balloon was glued firmly to the straw as shown at point X. When the air was released, the balloon moved forward. At point Y, all the air escaped from the balloon but it continued to move forward and finally stopped at point Z.

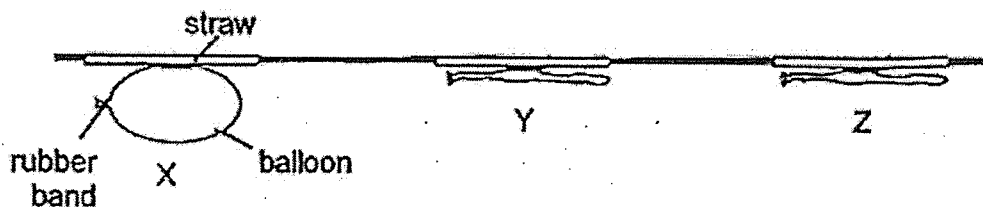

- (a) Give a reason why the balloon continued to move from point Y to point Z even when no more air was released. [1]

- (b) Explain why the balloon finally stopped at point Z. [1]

- (c) Using the same set-up, suggest a way to make the balloon move further than point Z. Explain your answer. [2]

End of Booklet B

SCORE	4
-------	---

Catholic High School

P6 Science Mid Year 2022

Answer Key

1. (?) (Missing ticks)	6. (3)	11. (1)	16. (4)	21. (3)	26. (1)
2. (2)	7. (3)	12. (3)	17. (1)	22. (2)	27. (2)
3. (4)	8. (2)	13. (2)	18. (2)	23. (4)	28. (4)
4. (2)	9. (1)	14. (3)	19. (2)	24. (2)	
5. (3)	10. (4)	15. 2 or 4 (Missing ticks)	20. (1)	25. (1)	

29 a.	Animal
b.	The fruit has <u>small indigestible seeds</u> . When animals eat the fruit together with the seeds, <u>they will move away from the parent plant</u> and <u>passed out the small indigestible seeds as droppings further away from the parent plant</u> . This helps in the dispersal of seeds for plant H.
30 a.	Set-up W. There is <u>less change in the mass</u> of the plant in W which shows that <u>less water is lost</u> from the leaves through the stomata. Since <u>more stomata is found on the underside of the leaves</u> , <u>more stomata are blocked</u> , the flask in Set-up W has the plant with leaves coated with oil on the underside.
b.	In the dark room without light, the <u>leaves will not take in water for photosynthesis</u> and <u>less water will be lost through the stomata</u> .
31 a.	As the height above sea level increases, the amount of oxygen available in the air decreases.
b.	When a person is at 8800m above sea level, there is <u>less amount of oxygen available in the air</u> compared to at sea level. His heart will have to <u>pump faster for blood containing digested food, oxygen and water through the blood vessels faster</u> to all parts of his body to receive the <u>same amount of oxygen</u> for respiration to <u>release the same amount of energy</u> for his body. Thus, he will have a faster heart rate.
32 a.	Water, oxygen (air), warmth
b.	Y. The mass of seed leaves will decrease as the stored food is being used up by the seedling during germination.
c.	Photosynthesis is the process whereby <u>water</u> and <u>carbon dioxide</u> is taken in by the plant to produce <u>food/sugar/glucose</u> and <u>oxygen</u> in the presence of <u>light</u> and <u>chlorophyll</u> .
33 a.	The widespread roots help to <u>anchor the mangrove trees firmly to the mud</u> to prevent it from being washed away from the rough tides and blown away by the strong winds.
b.	Suggestion 1: The parent plant can make food and provide more food for the germinating seed to grow better. Suggestion 2: The germinating seed can stay with the parent plant for a longer period of time to allow it to develop bigger and ensure a greater chance of successful water dispersal.

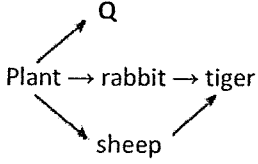
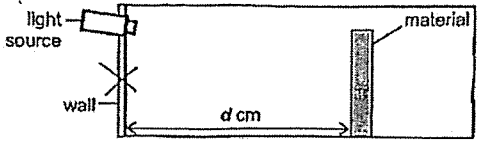
34 a.	
b.	<p>With the introduction of R, the <u>population of rabbits will decrease</u> as R feeds on more rabbits. Tigers would have <u>lesser rabbits to feed on</u> and will <u>feed on more sheep</u>. Thus, the <u>population of sheep will decrease</u>.</p>
c.	<p><u>Structural</u> adaptation. The stripes on the tiger's body helps it to <u>camouflage</u> and <u>blend in with the tall grass</u> so it <u>will not be spotted easily by the sheep</u>, for it to prey on the sheep more easily.</p>
35 a.	<p>Electrical Conductor</p>
b.	<p>When both wheels on the toy car touched the metal pins near iron rod A, it formed a <u>closed circuit</u> where <u>electric current can flow through the wire</u> and <u>iron rod A becomes an electromagnet</u>. The <u>like poles of iron rod A and the bar magnet facing each other will repel</u> as <u>like poles repel</u> and the toy car would move towards iron rod B.</p>
36 a.	 <p>Anywhere along the wall between the light source and the ground is acceptable.</p>
b.	<p>Using the light sensor, the <u>amount of light that is reflected</u> from the material to the wall can be <u>measured more accurately</u>.</p>
c.	<p>Material <u>W</u>. W is able to <u>reflect the most amount of light</u> from the car headlights so that the cyclist can be seen from the furthest distance and <u>be spotted most easily</u> by drivers at night to ensure that the cyclist will be safe on the road.</p>
37 a.	<p>Temperature is the measurement of how hot or cold something is.</p>
b.	<p>37°C</p>
c.	<p>Test-tube B is surrounded by other test tubes filled with water of the same temperature thus it <u>has lesser surface area in contact with the surrounding air</u> and <u>lost less heat to the surrounding air</u> compared to the water in test-tube A.</p>
38 a.	<p>By comparing set-ups A and B, <u>A is nearer to the lamp than B</u>. <u>A gains more heat from the lamp</u> and has a <u>higher rate of evaporation of water</u>. With <u>less water on A</u>, the <u>mass of the cloth A decreases faster over the same period of time</u>.</p>
b.	<p><u>Wind</u>. By comparing set-ups B and D, <u>D that is exposed to wind had more mass on its cloth</u> when compared to <u>B exposed to light at the same distance</u> of 60 cm. Thus, wind has a smaller effect than light on the <u>rate of evaporation of water</u> in the cloth. (can also compare C and A)</p>
39 a.	<p>(i) yes (ii) no (iii) yes (iv) closed</p>
b.	<p><u>B and D are electrical insulators / not conductors of electricity</u>. <u>A and C are electrical conductors/conductors of electricity</u>.</p>
40 a.	<p>Gravitational force</p>
b.	<p>Mass of the wooden block Amount of substance applied to the table.</p>

c.	<u>Z</u> . When substance Z was applied to the surface, it can <u>reduce the most friction between the block and the surface</u> and <u>least mass was required to move the wooden block across the table</u> . Thus, Z is most suitable to be applied on the board to <u>help the disc move the furthest across the board</u> .
d.	Applying the substance on the board would <u>reduce friction between disc B and the board</u> , and allowed disc B to move further after being hit.
e.	After disc B was being hit by disc A, the <u>same amount of kinetic energy of disc A was transferred to more kinetic energy of disc B</u> and converted to less heat energy. With more kinetic energy in B, it moved further.
41 a.	The balloon still <u>has kinetic energy</u> in it, allowing it to move from point Y to Z even when no air was released.
b.	When <u>all the kinetic energy of the balloon is converted to heat energy and sound energy</u> , the balloon stops moving.
c.	Inflate the balloon bigger. More elastic potential energy of the stretched balloon is converted to more kinetic energy in the balloon. With more kinetic energy, the balloon moved further.

